

Installation Note

**Agilent Technologies
E4407B and E4408B Spectrum Analyzers
APC 3.5 mm Input Connector (Option BAB)
Retrofit Kit**



Agilent Technologies

Part Number E4407-90001
Printed in USA August 2001

Notice.

The information contained in this document is subject to change without notice.

Agilent Technologies makes no warranty of any kind with regard to this material, including but not limited to, the implied warranties of merchantability and fitness for a particular purpose. Agilent Technologies shall not be liable for errors contained herein or for incidental or consequential damages in connection with the furnishing, performance, or use of this material.

Introduction

This procedure can be used to retrofit the APC 3.5 mm input connector (Option BAB) in E4407B or E4408B analyzers. One kit is provided for both model numbers.

Products Affected:	E4407B Spectrum Analyzer E4408B Spectrum Analyzer
Serial Numbers:	US00000000/US99999999 MY00000000/MY99999999
Option:	BAB
To Be Performed By:	<input checked="" type="checkbox"/> Agilent Technologies Service Center <input checked="" type="checkbox"/> Personnel Qualified by Agilent <input type="checkbox"/> Customer
Estimated Installation Time:.....	2.0 Hours
Estimated Verification Time:	3.0 Hours

Installation Kit Parts List

E4407B/E4408B (Option BAB) Retrofit Kit, E4407-60004^a

Quantity	Description	Part Number
1	APC 3.5 connector kit (A8J1)	E4407-60002
1	Cable assembly, RF IN/ATTN (W6)	E4404-20017
1	Adapter, APC 3.5 (f) to APC 3.5 (f)	5061-5311
1	Adapter, BNC (f) to SMA (m)	1250-1200
1	License key certificate	5964-5136 ^b
1	Letter	5964-5139 ^b
1	Firmware upgrade kit	Option UE2
1	APC 3.5 connector installation note	E4407-90001

a. This kit part number cannot be ordered. The part number is given only to identify the kit.

b. This part number cannot be ordered. The part number is given only to identify this part.

Tools Required

- T-10 TORX screwdriver
- T-15 TORX screwdriver
- Function generator
- Synthesized sweeper
- Digital voltmeter
- Power meter, dual channel
- RF Power sensor (2 required)
- Microwave power sensor
- 50 Ohm termination
- Power splitter
- 20 dB Attenuator (Option 1DS only)
- APC 3.5 (m) Cable
- APC 3.5 (m) to Type-N (m) Adapter
- APC 3.5 (m) to Type-N (f) Adapter
- BNC Tee (f,m,f)
- Dual banana to BNC (f) Adapter
- Adjustment software

The adjustment software may be obtained by ordering either the service documentation (Option 0BW) or N2717A Performance Verification and Adjustment Software.

Torque Settings

Tighten hardware to the following torque limits:

Item	Torque in Inch-Pounds
SMA connector	8.5
SMC connector	5.5
M3.5 T-10 TORX screws	14
M4 T-15 TORX screws	21
Pozidrive screws	14

WARNING Before you disassemble the instrument, turn the power switch to Standby and unplug the instrument. Failure to unplug the instrument can result in personal injury.

CAUTION Electrostatic discharge (ESD) can damage or destroy electronic components. All work on electronic assemblies should be performed at a static-safe workstation. Refer to the documentation that pertains to your instrument for information about static-safe workstations and ordering static-safe accessories.

Procedure

Removing the Dress Cover

1. Referring to [Figure 1](#), disconnect the analyzer from ac power (1).
2. Remove any adapters or cables connected to the front panel (2).
3. Position the handle (4) to the rear of the analyzer.
4. Carefully place the analyzer on the work surface with the front frame (3) facing down.
5. Remove the four screws (5) that hold the rear frame (6) and dress cover (7) in place.
6. Remove the rear frame (6) and dress cover (7) by sliding them towards the rear of the analyzer.

Figure 1 Dress Cover and Rear Frame Removal and Installation

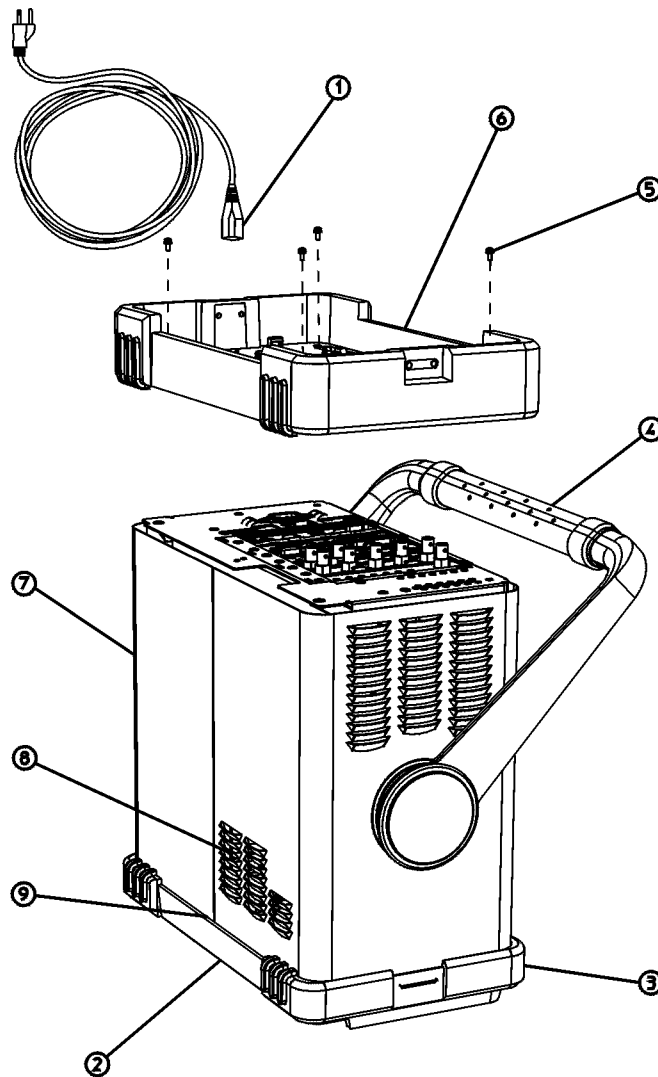

sl745b

Extending the Front Frame

The front frame assembly can be extended from the instrument without detaching any connections or removing the chassis cover.

1. Referring to [Figure 2](#), with the instrument still on its face, remove the five screws (1), two on the bottom side and three on the top of the instrument, that secure the front frame to the RF assembly and chassis cover.
2. Place the instrument with the top side facing up and remove the remaining two screws (2) that secure the front frame subpanel to the chassis.
3. Slide the front frame forward until it catches on the tabs on the sides of the chassis.

Removing the Front Frame

Figure 2 Front Frame Assembly Removal

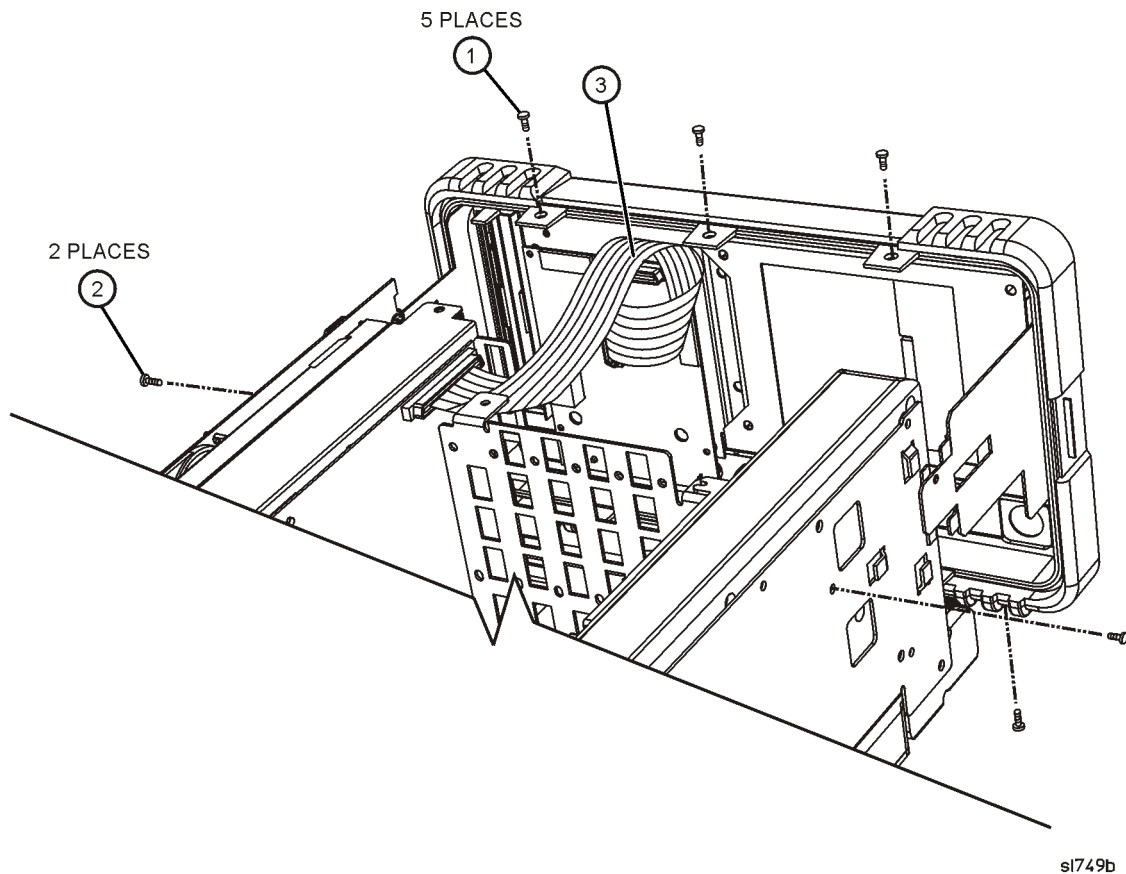

1. Disconnect the ribbon cable (3) from the front panel interface board.
2. Carefully pull the sides of the front frame subpanel away from the chassis and over the tabs on the chassis.
3. Slide the front frame forward to disengage from the chassis assembly.

Removing and Replacing the RF Input connector

1. Rotate the analyzer so the right side is resting on the table.
2. Referring to [Figure 3](#), locate W6 (1). W6 is a semi-rigid coax cable connected between the A8A5 input attenuator (2) and the A8J1 input connector (3).

Figure 3 Replacing the Input Connector and Cable

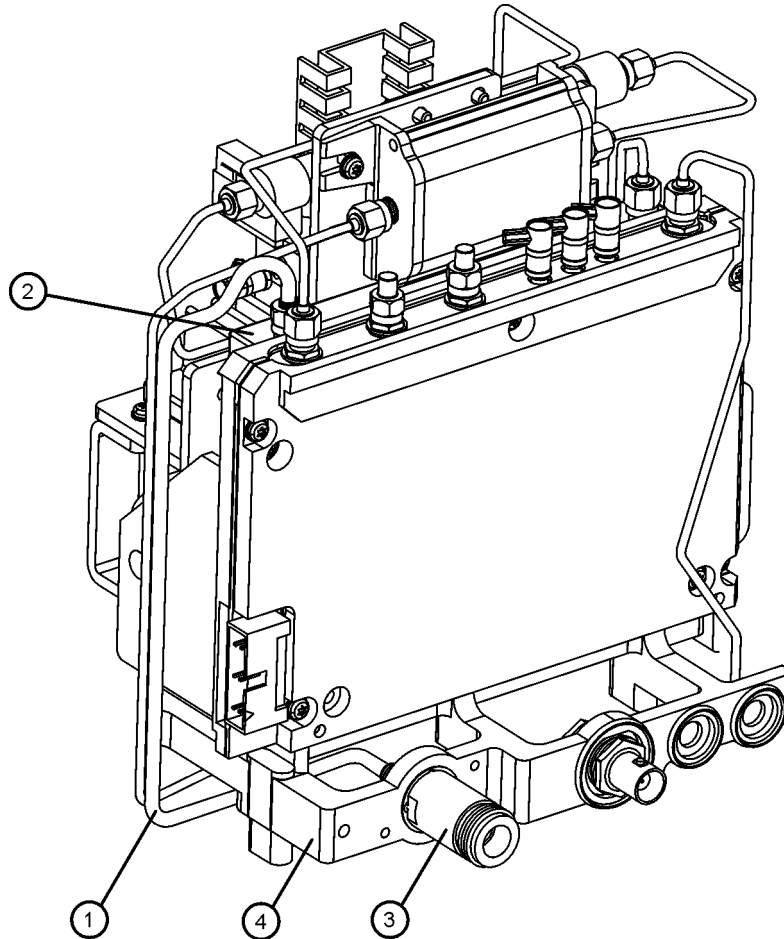

si711bb

3. Remove the A8J1 input connector from the midweb (4).
4. Attach the APC 3.5 mm input connector included in this kit to the midweb (4) using the two 3.0 mm screws provided in the connector kit.
5. Connect the new W6 semi-rigid cable, included in the kit, between the A8A5 input attenuator (2) and the APC 3.5 mm input connector (3). Tighten the SMA connectors to 8.5 inch pounds.

Replacing the Front Frame

1. Align the front frame subpanel rails with the chassis as shown in [Figure 2](#).
2. Referring to [Figure 2](#), connect the ribbon cable (3) to the front frame assembly.
3. Carefully slide the front frame toward the chassis, assuring the ribbon cable is not pinched between assemblies, and the RF input connector lines up correctly with the opening in the front frame.

NOTE Make sure the water seal is still in place around the input connector (and around the A2 tracking generator connector if the instrument is an Option 1DN) before reinstalling the front frame assembly.

4. Referring to [Figure 2](#), replace the screws (1) that secure the front frame to the chassis. Tighten them to 9 inch-pounds.

Replacing the Dress Cover

1. Referring to [Figure 1](#), place the spectrum analyzer on the work surface with the front frame (3) facing down.
2. Replace the instrument outer case and rear frame assembly (6), matching the grill (8) on the bottom of the case to the bottom of the analyzer.
3. Fit the leading edge of the case completely into the slot (9) on the back of the front frame assembly.
4. Replace the four screws (5) to fasten the rear frame to the instrument. Tighten them to 21 inch-pounds.

Loading the New Firmware

1. Turn on the analyzer and wait for the power-on alignments to complete. Check that there are no error messages displayed.
2. Press **System, More, Show System**. Note the firmware revision. If the firmware revision is A.04.00 or later, proceed to “Activate the Option BAB License Key.”
3. If your firmware revision is earlier than A.04.00, you must upgrade your analyzer firmware. Refer to the installation note supplied with the firmware upgrade kit included in this kit.

Activating the Option BAB License Key

The license key supplied in this kit allows you to activate APC 3.5 mm input connector (Option BAB).

1. Press **System, More, More, Licensing, Option**
2. When you press **Option**, the alpha editor will be activated. For instructions on using the alpha editor, refer to the user’s guide.
3. Use the alpha editor to enter the three-character designation for the option, in this case, “BAB”, that you want to activate.
4. Press **Done** on the alpha editor menu.
5. Press **License Key**. When you press **License Key** the alpha editor will be activated.
6. Use the alpha editor and the numeric keypad to enter the 12-character license key number (for example: D7C374DABD5B) for the option that you want to activate.
7. Press **Done** on the alpha editor menu.
8. Press **Activate** to turn on the option.

Adjustments and Performance Verification

1. Verify that Option BAB was activated by pressing **System, More, Show System**. Verify that there is an entry which reads, “BAB: APC 3.5 mm Connector”.
2. Perform the Frequency Response Adjustment, located in the Adjustment Software.
3. Perform the following performance verification tests, located in the calibration guide:
 - Frequency Response
 - Displayed Average Noise Level
 - Residual Responses
4. If you have problems performing either of these tests, get in touch with the nearest Agilent Technologies sales and service office listed in the troubleshooting chapter of the user’s guide.

Using the Adapters Included in this Kit

The APC 3.5 (f) to APC 3.5 (f) adapter may be used as a “connector saver” to prevent damage to the APC 3.5 connector on the instrument. This adapter should also be used with the SMA (m) to BNC (f) adapter. This is especially useful when connecting a short BNC cable to the AMPTD REF OUT for performing RF Alignments.